

Made in USA



XCAL
TOOLS



Distributed By:



www.dmcwearparts.com

Email: kody@dmcwearparts.com

Phone: (605) 840-8082



SUPERIOR QUALITY

XCAL TOOLS takes pride in manufacturing and selling a full line of road planing, soil stabilization, reclaiming, grading, trenching and foundation drilling bits and carbide tooling products that are American-made. Our inhouse operations gives us the flexibility to quickly test and adapt to changing environments and customer needs. Our cost effective production methods, allows us to provide a exceptional product of the highest quality.



SERVICE AND INNOVATION

For over 20 years, our carbide producer XCAL INDUSTRIES, has been producing high quality carbide for the mining, roof drilling, snow and ice removal, road planing, wear products and metal cutting blanks, producing over fifty grades of cemented carbide and the capability to develop extra coarse, tougher grades to meet the demands of the industry.

These affiliates of JENNMAR, in collaboration with each other, can provide you with superior quality products and unmatched customer service. Our commitment to the customer is guided by three words; SAFETY, SERVICE, and INNOVATION. It's these words that form the foundation of our business. It's who we are.





Table of Contents

GRADING

CARBIDE TIPS	8
S-2000	9
S-2000 SQUARE WASHERS	11
ACCESSORIES	15

22MM & S-2000 BOARDS

G01	10
G28	10
G27	10
GB223658	10
GB224858	10
GB223634	10
GB224834	10

22MM & S-2000 BOARDS

GW28	12
GW70	12
GWX28	12
GB223658G	12
GB224858G	12
GB223634G	12
GB224834G	12

25MM & S-2000 BOARDS

GW2523	13
GB2536	13
GB2548	13
GW3520	14
GB3548	14

Carbide Tips

We are an ISO 9001 certified facility that offers a wide range of carbide tips to match the various challenges that you might face. Producing over fifty grades of cemented carbide and the ability to create new ones, we can find a carbide grade to meet your needs. Our versatility helps us to check and respond easily to evolving conditions and customer needs. All of our tips provide superb penetration and maximum productivity – regardless of whether you work in soft, medium-hard or extremely hard and demanding conditions.



Valve-Seat Carbide Tips

Valve-Seat carbide tips have a valve-seat braze joint for increased strength and shear resistance. The tips provide excellent penetration, and the large carbide shoulder gives excellent protection against steel wash. These tips are best suited for use in soft to medium materials or conditions.



Proudly made in the U.S.A.



S-2000



The S-2000 is an innovative road grading system that uses rotating, replaceable tungsten carbide tools as a cutting edge, ideal for maintaining a variety of non-hard surfaced roads (e.g., ice, dirt, gravel, hauling roads, roads including public road districts, private construction contractors, federal land management, logging and mining roads). It works by utilizing a replaceable conical tool installed in a heat-treated adapter board that allows better wear resistance and improved cutting capability over conventional steel blades and can be mounted on a motor grader in place of a conventional blade. It can also be mounted to an under body blade on a truck or a rear blade on a tractor.

Features and Benefits:

- **Lower Grading Costs:** Reduced equipment costs with a blade life equal to 5 to 15 sets of conventional blades.
- **Negligible Downtime:** Easy handling and installation in the field with no heavy lift required.
- **Improves Road Surface:** Cuts road surface instead of scraping providing improved mix of materials.
- **Increases Productivity:** Reduces dust and brings larger gravel particles to top of road surface.
- **Cost Effective Asphalt Removal:** Easily removes asphalt to desired profile and granulates material to a uniform size to be re-used for fill.
- **Excellent Ice Removal System:** Cutting action produces a grooved surface providing improved road traction.

Applications:

- Gravel reclamation and maintenance.
- Oil road reclamation.
- Asphalt planing or following a milling machine to remove final layer of asphalt.
- Removal of potholes, washboards and rebuilding the crown for proper drainage on dirt or gravel roads.
- Removal of temporary pavement marking.
- Snow removal and ice shaving.



Proudly made in the U.S.A.

Grading

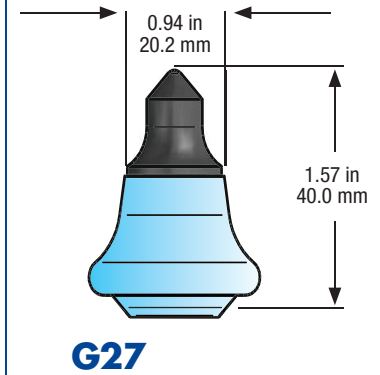
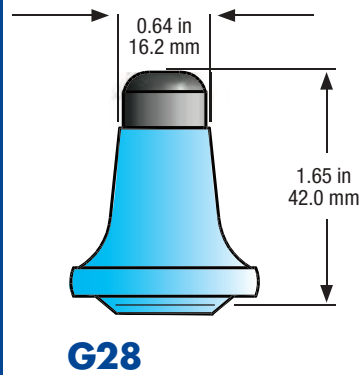
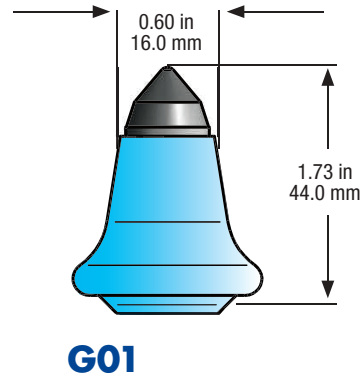

Features:

- “Gear Tooth” washer protects board mating face
- Retainer compressed for easy installation
- Multiple tip options for different applications

Part Number	Shank (in, mm)	Tip Diameter (in, mm)	Base Diameter (in, mm)	Gauge (in, mm)	Pieces per Box	Pieces per Pallet
G01	0.87 in 22 mm	1.11 in 12.8 mm	0.60 in 16.0 mm	1.73 in 44.0 mm	65	3900
G28	0.87 in 22 mm	0.64 in 16.2 mm	0.64 in 16.2 mm	1.65 in 42.0 mm	65	3900
G27	0.87 in 22 mm	0.40 in 10.1 mm	0.94 in 20.2 mm	1.57 in 40.0 mm	65	3900

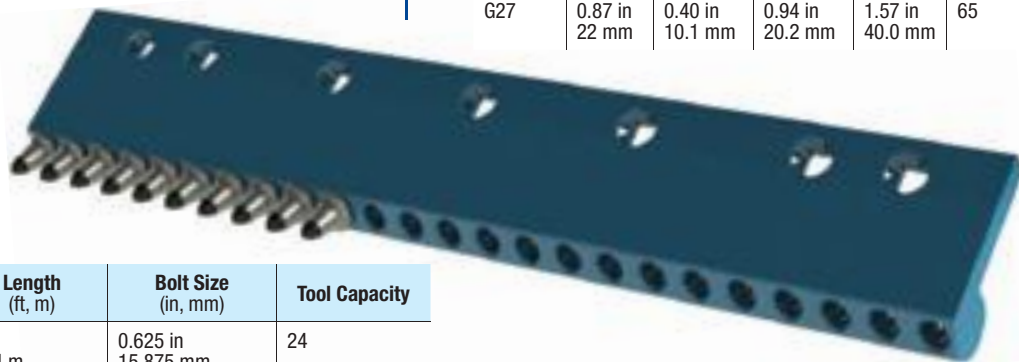

Part Number	Length (ft, m)	Bolt Size (in, mm)	Tool Capacity
GB223658	3 ft .914 m	0.625 in 15.875 mm	24
GB224858	4 ft 1.219 m	0.625 in 15.875 mm	32
GB223634	3 ft .914 m	0.75 in 19.05 mm	24
GB224834	4 ft 1.219 m	0.75 in 19.05 mm	32

Features:

- Tool bores feature internal clip groove for use with any style retainer
- Multi-piece assembly allows for manageable installation



Proudly made in the U.S.A.



S-2000 Square Washers

Benefits:

- New "gear tooth" arrangement prevents washers from sliding and opening a gap between the tools.
- Compatible with old-style square washer and end protectors.
- Pre-compressed retainer for easy installation.
- Enhances tool rotation eliminating premature wear of carbide tips.
- Eliminates washer rotation, preventing wear between washer and mating surface.
- Provides support and stability to the tool with an extruded cone that fits neatly into the bore of the adapter board.



Hexagon design makes install and removal **QUICK & EASY!**

- The S-2000 square washers act as a replaceable "armor plate" wear surface preventing material buildup to allow the tool to rotate freely for improved cutting ability. The square design eliminates washer rotation preventing wear between the washer and the adapter board.

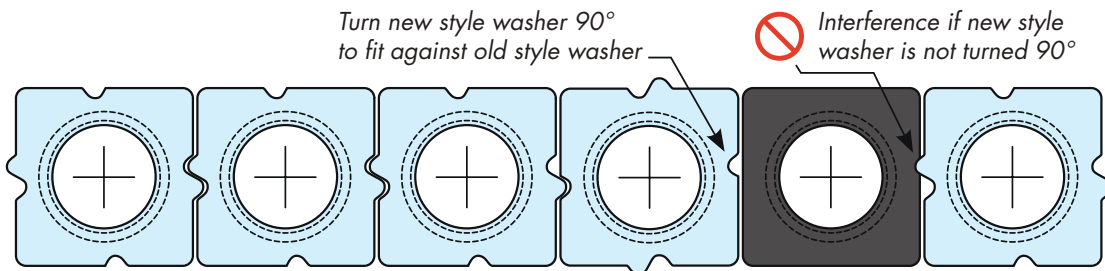

S-2000 Square Washers With Interlocking Feature (For 22 mm And 25 mm Tools) *Patent-Protected Square Washer

Why the angle makes a difference:

The unique operating angle of the board, that is 20° back from vertical, creates a mixing action that produces a homogeneous blend of material. This can significantly reduce the need to add new gravel.

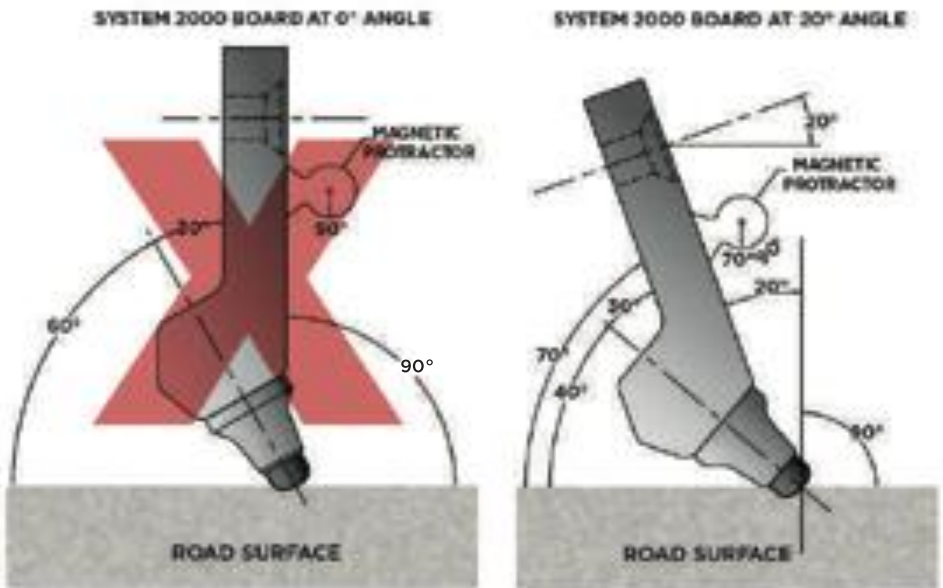

Proudly made in the U.S.A.



Grading

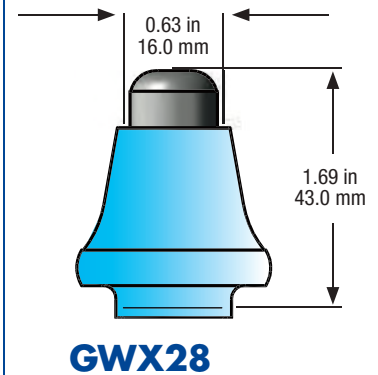
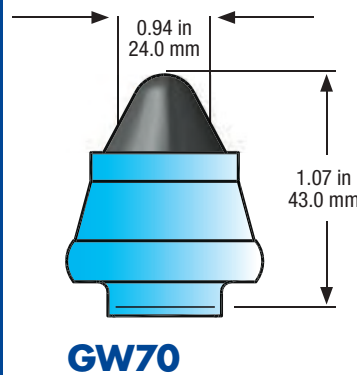
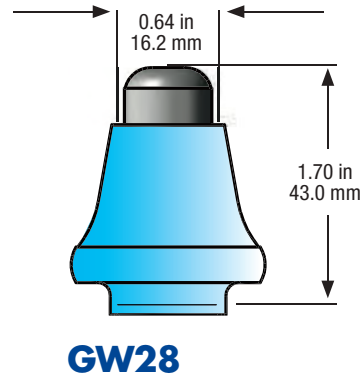

Features:

- Square washer eliminates washer rotation, preventing wear between washer and mating surface.
- Provides support and stability to the tool with an extruded cone that fits neatly into the bore of the adaptor board.

Part Number	Shank (in, mm)	Tip Diameter (in, mm)	Base Diameter (in, mm)	Gauge (in, mm)	Pieces per Box	Pieces per Pallet
GW28	0.87 in 22 mm	0.64 in 16.2 mm	0.64 in 16.2 mm	1.70 in 43.0 mm	50	3000
GW70	0.87 in 22 mm	N/A	0.94 in 24.0 mm	1.07 in 43.0 mm	40	2400
GWX28	0.87 in 22 mm	0.64 in 16.2 mm	0.63 in hex 16.0 mm hex	1.69 in 43.0 mm	50	3000

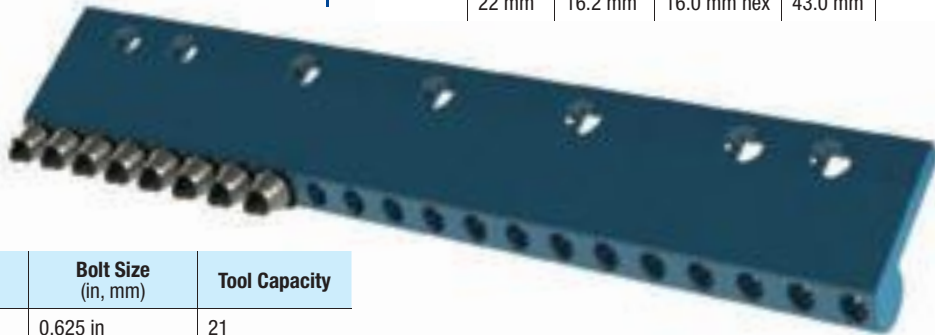

Part Number	Length (ft, m)	Bolt Size (in, mm)	Tool Capacity
GB223658G	3 ft .914 m	0.625 in 15.875 mm	21
GB224858G	4 ft 1.219 m	0.625 in 15.875 mm	28
GB223634G	3 ft .914 m	0.75 in 19.05 mm	21
GB224834G	4 ft 1.219 m	0.75 in 19.05 mm	28

Features:

- Tool bores feature internal clip groove for use with any style retainer
- Multi-piece assembly allows for manageable installation



Proudly made in the U.S.A.



Grading

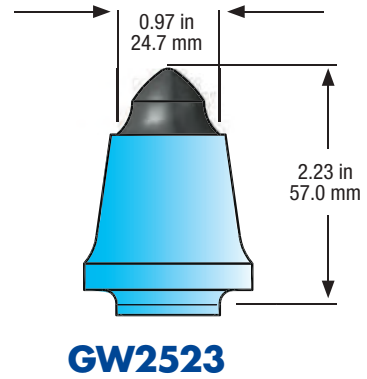

Features:

- "Gear Tooth" washer protects board mating face
- Pre-compressed retainer for easy installation
- Multiple tip options for different applications

Part Number	Shank (in, mm)	Tip Diameter (in, mm)	Base Diameter (in, mm)	Gauge (in, mm)	Pieces per Box	Pieces per Pallet
GW2523	0.98 in 25 mm	0.68 in 17.3 mm	0.97 in 24.7 mm	2.23 in 57.0 mm	30	1800

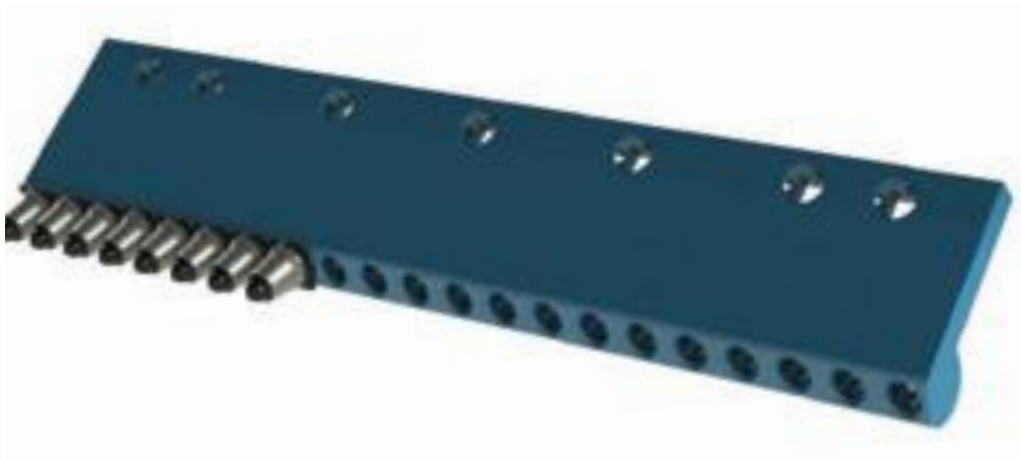

Part Number	Length (ft, m)	Bolt Size (in, mm)	Tool Capacity
GB2536	3 ft .914 m	0.75 in 19.05 mm	21
GB2548	4 ft 1.219 m	0.75 in 19.05 mm	28

Features:

- Tool bores feature internal clip groove for use with any style retainer
- Multi-piece assembly allows for manageable installation



Proudly made in the U.S.A.



Grading

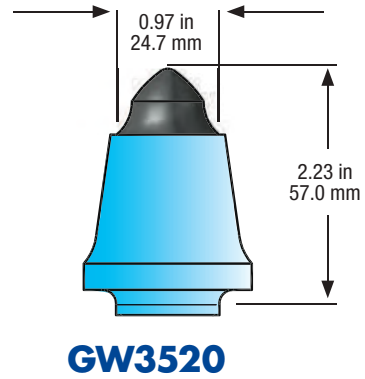

Features:

- Heavy Duty Body
- Square washer enhances tool rotation
- Serves as a replaceable "armor plate" wear surface

Part Number	Shank (in, mm)	Tip Diameter (in, mm)	Base Diameter (in, mm)	Gauge (in, mm)	Pieces per Box	Pieces per Pallet
GW3520	0.98 in 25 mm	0.68 in 17.3 mm	0.97 in 24.7 mm	2.23 in 57.0 mm	30	1800



Part Number	Length (ft, m)	Bolt Size (in, mm)	Tool Capacity
GB3548	4 ft 1.219 m	1 in 25.4 mm	19

Features:

- Tool bores feature internal clip groove for use with any style retainer
- Multi-piece assembly allows for manageable installation



Proudly made in the U.S.A.





Accessories



CURVED KNOCK OUT PUNCH - Tool remover with carbide tip for extended life.

Part Number
Product Code

JMXA-CKP



AIR HAMMER PUNCH - 3/8" chuck. For removal of conical tools from blocks. Hardened tip provides long life. Fits light-duty air-hammer guns with 3/8-inch chucks.

Part Number
Product Code

JMXA-AH12



AIR HAMMER PUNCH - 1/2" chuck. For installation of conical tools into blocks. Fits light-duty and heavy-duty air-hammer guns with 1/2" chuck.

Part Number
Product Code

JMXA-AH38



Proudly made in the U.S.A.





15020 INDUSTRIAL PARK ROAD
BRISTOL, VA USA
(276)-644-3520
WWW.XCALTOOLS.COM